

Futures Industry Association

XML Capabilities in Your Environment

Leonardo Llamas

IBM

Advanced Technical Support

Rochester, MN

Agenda

Define XML

- What is XML
- Its Origin

XML's Value

- Business Value
- Technical Value

Look at XML & Related Components

XML on iSeries

Demos

Notes:

We're going to start out with a section on what is XML and where did it come from...

With that background, we can move into a discussion about what is XML good for and why would anybody want to use it.

After that discussion, we'll dig a little deeper into XML and some of the related components required for an XML implementation

Having a bigger picture of the XML world, we'll then explore how the iSeries supports an XML implementation.

Finally, we'll close on a discussion of where XML on the iSeries will be going in the future.

Objectives

Understand Basics of XML

Understand Value of XML in Business Applications

Understand XML Related Components

XML on iSeries

What is XML

XML == eXtensible Markup Language

Heritage

- a subset of SGML (Standard Generalized Markup Language)
 - based on GML (Generalized Markup Language)
 - intended for document processing and publishing
- a sibling to HTML (HyperText Markup Language)
 - used to format information for the Web

XML describes and delivers data

- goes beyond the limits of HTML
- developer can define own markup language
- separates the content from the presentation (formatting)
- allows precise declaration of content
- allows a standardized strategy to define content of documents & databases

Notes:

XML is an abbreviation for eXtensible Markup Language.

XML was created from SGML - SGML is a document language, intended for creating and managing large and complex documents. SGML is used by large corporations and the government to maintain their documents.

XML, like HTML, is intended for information delivery on the WEB. HTML is a very popular means of delivering information to the Web and HTML is simple to learn and to use. However it is becoming inadequate for the volume and variety of information available on the web today.

One of XML's objectives is to be a vehicle for delivering information on the web, enhancing and more often replacing the HTML text available today. HTML and XML are compared later in this presentation.

The real power of XML, (like SGML) is the ability to create tags that have **meaning** to each particular application, unlike HTML which has a fixed tag set.

XML allows the data to retain its meaning and is not concerned with the presentation of the data like HTML. XML has associated components that support the HTML type of presentation (these are discussed later).

XML's real power is:

- **retaining the meaning of data outside the structure**
- **being both platform and vendor neutral**
- **defined as a representation for universal data exchange**
- **extensibility -->> create new dialects and add to existing dialects and documents**

W3C - World Wide Web Consortium

W3C

- organization to establish specifications for Web technologies ensuring the highest degree of utility and interoperability
- a number of companies (Adobe, HP, IBM, MS, Netscape, Sun, ...) represent a variety of requirements and perspectives
- create and review specifications for XML and related components
- the W3C web page for a complete set of reference material is <http://www.w3.org>

Notes:

The World Wide Web Consortium has the task of both defining and validating the specifications for XML and XML related technologies. It is composed of companies in a variety of industries including:

- IBM & Microsoft (IT)
- Oracle (Database)
- Netscape (Internet)
- Adobe (Publishing)

to ensure their interests are considered in the evolution of these specifications.

XML vs HTML

XML

- **Uses <tag> & </tag> style**
- **Tagged markup for information**
 - Focused on data structure
 - Data retains meaning
- **Extensible - can define new tags**
- **Descriptive markup**
 - specific search criteria
- **Stringent syntax**
 - end tags required
 - <paper color="red"></paper>
 - or, <paper color="red"/>
 - element nesting enforced
 - case-sensitive elements
- ***Associated components***
- **Highly reusable documents**
- **Requires newer browser**
 - Internet Explorer 5.0+
 - Netscape 4.0+

HTML

- **Uses <tag> & </tag> style**
- **Tagged markup for text**
 - Focused on presentation
 - Data is text (limited reuse)
- **(Relatively) Fixed set of tags**
- **Document tagging**
 - too many hits
- **Loose syntax**
 - end tags assumed
 - nesting errors effect display
- **Simple and complete**
- **Single use -- for Web**
- **Works with any browser**

Notes:

This chart show the difference between XML and HTML.

- Both XML & HTML are tagged markup languages
 - however XML retains the meaning of the information while HTML focuses solely on the presentation
 - XML data retains its meaning so there is a wide opportunity for reuse of the information
- By having the ability to define new tags within XML - tags are defined that specifically describe the data between the tags
 - for example an XML tag maybe `<book title>` while in HTML it would be expressed as `<H1>`
- These descriptive tags allow specifying more discrete searches because you state both the tag name and the content (data) in the search criteria
 - for example if you wanted books written by George GoldFarb you could build a search looking for author name of George Goldfarb this would retrieve only books by that author
- There are a small set of rules for creating an XML document unlike HTML:
 - rules include having both a start and end tag with the same name.
 - tags are case sensitive and space sensitive they must be exact `<BOOK>` does not equal `<book>`
 - nesting of elements is possible and is enforced
- Unlike HTML which is usable by any browser - XML has associated components which we will talk about later
- Highly reusable - representing data as an XML document allows that document to be used in a variety of implementations (EDI environments, on the web, transformed to other dialects...)
- XML requires newer browsers to view an XML document - HTML works with any browser.

Looking at XML & HTML

```
<?xml version="1.0"?>
<catalog>
  <product category="equipment">
    <number>SE1357908</number>
    <name>Tennis Racket R13</name>
    <description>Tennis Racket Pro R13
      </description>
    <price currency="USD">148.00</price>
    <brand>Wilson</brand>
    <color>granite</color>
    <weight unit="pounds">1.25</weight>
    <availableQuantity>14</availableQuantity>
  </product>
  <product category="clothing">
    <number>SW5782098</number>
    <name>Running Shorts</name>
    <description>Running Shorts - Nylon
      </description>
    <price currency="USD">37.00</price>
    <brand>Nike</brand>
    <color>midnight blue</color>
    <size>small</size>
    <availableQuantity>34</availableQuantity>
  </product>
</catalog>
```

```
<html>
<table>
  <tr>
    <td>SE1357908</td>
    <td>Tennis Racket R13</td>
    <td>Tennis Racket Pro R13</td>
    <td>148.00</td>
    <td>Wilson</td>
    <td>granite</td>
    <td>1.25</td>
    <td>14</td>
  </tr>
  <tr>
    <td>SW5782098</td>
    <td>Running Shorts</td>
    <td>Running Shorts - Nylon</td>
    <td>37.00</td>
    <td>Nike</td>
    <td>midnight blue</td>
    <td>small</td>
    <td>34</td>
  </tr>
</table>
</html>
```

Notes:

Each tag set with content within XML is considered an element and has specific meaning for the data associated with it.

For example `<name>Tennis Racket R13</name>` is considered an element. XML elements can be nested and are structured according to the specific needs of the developer and the data. This is very helpful for retaining the representation of that data in a database.

Later, I will talk about how to control the content of an XML document and how rules can be applied to a XML document.

HTML delivers a presentation style as specified by its tag set. Search engines processing XML documents using both the tag name and the specific search criteria can make more precise searches for information. Intelligent agents using this same concept will be more realistic and usable in the future.

The `<?xml version="1.0"?>` tag specifies the version of XML being used. "xml" is a reserved word, with a version number (1.0 is the current specification).

Each tag is composed with a start `<tag>` and an end tag `</tag>` with exactly the same name and case. The tag names are case sensitive - so `<Product>` and `<product>` are two different tags in XML.

Tags can be nested to more closely represent the data.

An empty tag (used for structure purposes) uses the `<empty/>` construct. An empty tag may have attributes
Example: `<Price dollars="5.00"/>` where the `"/"` denotes the end.

Well-formed XML

A small set of rules define the basic syntax for XML documents

- Required 1st line `<?xml version="1.0"?>`
- Tag with corresponding end tag `<tag>data</tag>`
- Tag **attributes**
Shortcut, if no data `<tag attribute="x">data</tag>`
`<tag attribute="x"/>`
- Proper nesting and outermost tag
- Example

```
<?xml version="1.0"?>
<goodemployees>
<employee>
  <fullname>Leonardo LLames</fullname>
  <ID>666666</ID>
  <hiredate status="permanent">01/01/2002</hiredate>
</employee>
. . . . .
</goodemployees>
```



All XML documents must follow these basic syntax rules.

The first line is boilerplate.

For every tag, there should be a corresponding end tag.

Attributes can also be specified within a tag. Generally, there is a finite set of valid attribute values for a given tag. In the example, an attribute of "status" is used within the "hiredate" tag. The value of "status" in the example is "permanent". Since this is employee data, one can conclude that the other valid "status" values can be "temporary", "contractual", etc.

Note that if there is no data provided between the tag and the end tag (assuming that it is optional), the tag and end tag pair can be specified using the given syntax of `<tag attribute="x"/>`. In the example, if the "hiredate" value is optional and not provided, the statement `<hiredate status="permanent">01/01/2001</hiredate>` can be written as `<hiredate status="permanent"/>`

Proper element nesting is also enforced. Tag and end tag pairs cannot cross each others' boundaries. For instance, `<fullname><ID>Leonardo LLames</fullname> 666666</ID>` is obviously incorrect.

Valid XML Documents

How do we specify:

- tag names that are allowed? Why "employee" and not "empl"?
- which tags can nest within other tags?
- required tags vs. optional tags?
- one occurrence, or any number of occurrences?
- default values of attributes?
- etc.?

A particular XML is called "**vocabulary**" and is expressed in either **DTD** or **XML Schema**.

A "**valid**" XML document conforms to the basic syntax rules (is well formed) AND complies with a specific DTD or XML Schema

Cross-Industry/Tech XML Vocabularies

Search Schema in XML.org Registry - Netscape

File Edit View Go Communicator Help

Bookmarks Location: <http://www.xml.org/xml/registry.jsp> What's Related

XML XML XML XML XML XML XML XML

XML.ORG the **XML industry portal**

XML in Industry XML Registry News Calendar
Marketplace Resources MyXML.org Sponsors

HOSTED BY OASIS

Search Schema Submit Schema

Sign Me UP
About XML.org
Advisory Board
OASIS Committees
XML FAQ
Contact Us
xml-dev Mail List
Link to XML.org

Search XML.org find it

Search Schema [about XML.org Registry](#)

Search Schemas/DTDs in XML.org Registry:

Keyword:

Industry: All Industries

Last Update: Since Inception

Document Type: All Document Types

Search

[Registry of latest ebXML specifications](#)

Registered Submissions By Industry

Accounting (5)	ERP (1)	Publishing/Print (3)
Aerospace (1)	Education (8)	Real Estate (2)
Arts/Entertainment (6)	Energy/Utilities (17)	Robotics/AI (2)
Astronomy (4)	Financial Service (21)	Science (7)
Automotive (4)	Food Services (2)	Security (1)
Banking (1)	Geography (2)	Software (8)
Biology (4)	Healthcare (6)	Supply Chain (5)
Business Services (3)	Human Resources (9)	Telecommunications (5)
Catalogs (1)	Industrial Control (1)	Transportation (2)
Chemistry (3)	Internet/Web (7)	Weather (1)
Construction (2)	Manufacturing (4)	XML Technologies (18)
Databases (1)	Multimedia (6)	
E-Commerce (8)	News (3)	
EDI (2)	Other Industry (4)	

Document: Done

Start N... flg F... S... r... 2:57 PM

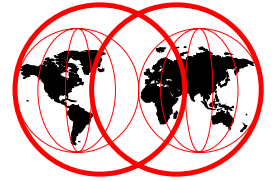

Looking at XML & Friends

XML Enablers

XML represents data and information about that data

XML works with other related specifications (Enablers)

- **DTD** Document Type Description
 - defines valid XML Document syntax
 - well formed (w/o DTD) vs valid (DTD used)
- **XML Schema**
 - an improved XML definition and validation language
 - functional superset of DTDs
- **XSL** eXtensible Stylesheet Language
 - defines how to format and transform XML data streams
 - more robust than CSS Cascading Style Sheet
- **XML Parsers**
 - programs used to translate XML into computer usable tree structure
 - provides interface for applications to view & update XML documents
 - validating or non-validating, different programming languages, DOM or SAX

Notes:

XML focuses on representing data without losing the ability to describe that information. But XML is not complete by itself, enablers are necessary.

The W3C have prepared written recommendations for the DTD, XML Schema, XSL and Parser and are no longer just "working specs".

Some of these are currently being used in products and tools today.

These enablers may be enhanced/extended by other enablers that are more clearly defined or robust. However, the effort of creating the XML environment is not wasted.

DTD Document Type Description

Optional but should accompany a XML document

- ensures absolute data consistency

Defines the rules of the document

- which elements and attributes (if any) must be present
- structural relationship between the elements

Helps to validate data being received by an application

XML

```
<books>
<book type="fiction">
  <title>          </title>
  <author>         </author>
  <isbn>           </isbn>
  <reader-level>  </reader-level>
</book>
</books>
```

DTD

```
<!-- books.dtd -->
<!-- books is the root of the document -->
<!ELEMENT books (book+)>
<!ELEMENT book ( title, author+, isbn,
                reader-level? )>
<!ATTLIST book
  type (fiction | nonfiction) "fiction">
<!ELEMENT title (#PCDATA)>
<!ELEMENT author (#PCDATA)>
<!ELEMENT isbn (#PCDATA)>
<!ELEMENT reader-level (#PCDATA)>
```

Notes:

A DTD is used to define a valid XML document.

A DTD is used to define

- valid vocabulary of element type names for use in tags of a document
- nesting rules and valid attributes
- allows validation by XML Parser

A DTD declares what constitutes valid markup for a specific document type and it declares the rules about the elements used (ie. relationships, occurrences, valid values...). A DTD can be as simple as the data represented in the XML document.

An XML document is validated by a parser having a DTD because the parser can apply constraints to the elements within the DTD.

DTD Document Type Description

<!-- comments -->

<!ELEMENT books (book+) *(books contain book objects, in this case 1 or more)*

<!ELEMENT book (title, author+, isbn, reader-level?)

(book contains these child elements -

- *title and isbn ("no indicator" means appears once)*
- *author - must be present (+ = one or more)*
- *reader level optional (? = once or not at all)*

<!ATTLIST book
type (fiction | nonfiction) "fiction"> *Attributes for book element, default is fiction*

<!ELEMENT title (#PCDATA)> *(#PCDATA - Parse Character Data - a reserved name - denotes character content)*

<!ELEMENT author (#PCDATA)>

<!ELEMENT isbn (#PCDATA)>

<!ELEMENT reader-level (#PCDATA)>

Notes:

This example shows the basic syntax of a DTD for our book XML doc.

DTDs provide a specific set of rules to follow that we will not study here. But as an overview, notice after the book element in the list, each element has a specific nomenclature (a "+", a "?" or a blank):

- this nomenclature specifies the rules of the occurrence of an element within the document.
- "+" - the element must occur once and may be multiple
- "?" - the element may occur only once or not at all
- " " (blank) - the element must occur once
- "*" - the element may exist once, multiple or not at all
- "choice1|choice2" - the element must occur once and can only be "choice1" or "choice2"

Each element is listed individually to allow definition of its own characteristics. These characteristics can be #PCDATA (for Parse Character Data) as shown in our example for "title". Specific values or other keywords (like ANY which allows any data type, or EMPTY which has no value but can be a place holder for future use or indicate another level in the structure).

Along with #PCDATA can be sub elements which allow definition of specific valid values. For example, reader level may only allow values like beginner, intermediate or advanced as valid values.

XML Schema

W3C Recommendation

Functional superset of DTD's

Allow additional constraints to be defined

- strong type support, e.g., data and numeric element types
- min/max length
- min/max values
- pattern, enumeration, precision, etc.

Unlike DTDs, XML Schemas are well formed XML documents

- DTDs' #PCDATA can be **any** string of characters

XML Schema

Example: simpleType with min / max length

- Defines a new string type, called streetaddress that may contain 1 to 30 characters
- Uses facets minLength and maxLength to constrain the length

```
<simpleType name="streetaddress"  
           base="string">  
  <minLength value="1"/>  
  <maxLength value="30"/>  
</simpleType>
```

XML Schema

The Schema

```
<schema>  
  
<element name="pOrder" type="POrder"/>  
  
<complexType name="POrder">  
  <element name="shipTo" type="Address"/>  
  <element name="billTo" type="Address"/>  
  <attribute name="poDate" type="date"/>  
</complexType>  
  
<complexType name="Address">  
  <element name="name" type="string"/>  
  <element name="zip" type="integer"/>  
</complexType>  
  
</schema>
```

An Instance

```
<pOrder poDate="1999-05-20">  
  
  <shipTo>  
    <name>Jo</name>  
    <zip>95944</zip>  
  </shipTo>  
  
  <billTo>  
    <name>Jo Sr.</name>  
    <zip>20012</zip>  
  </billTo>  
  
</pOrder>
```

XSL eXtensible Stylesheet Language

Has two roles

- *transform* an XML document into another document or HTML
 - can create new formatting tags and properties
- *render* XML data for presentation
 - fonts, size, color, alignment
 - provide rules for ordering presentation

Value

- more formatting flexibility based on context or element position

Popular Stylesheet Engines (Java based)

- LotusXSL
- Xalan, open-source (Apache.org) version of LotusXSL

Notes:

XSL is being used to format and transform XML documents.

Transforming - Stylesheets can specify the rules for transforming an XML document into another XML Dialect or HTML. This allows a consistent form of the XML document to provide a base for a variety of other documents, which are used by a variety of devices and applications.

Formatting - different XSL files can be created for the same XML Document. This allows the user to select their personal favorite as a means to display the information. For example, one person may prefer to see information represented in a table which someone else may like an indented list. XSL takes XML far beyond HTML because of this particular feature. The order of the information can be modified within the XSL Stylesheet as well, which makes the whole environment more user friendly.

XSL Example - formatting to Browser

```
<?xml version="1.0"?>
<xsl:stylesheet version="1.0"
xmlns:xsl="http://www.w3.org/1999/XSL/Transform">
<xsl:output method="html" indent="yes"/>

<xsl:template match="/">
  <xsl:apply-templates select="books/book"/>
</xsl:template>

<xsl:template match="books/book">
  <html>
  <head> <title>Book Club List</title> </head>
  <body>
    <h1><xsl:value-of select="title"/></h1>
    <xsl:apply-templates select="author"/>
  </body>
  </html>
</xsl:template>

<xsl:template match="author">
  <p><xsl:value-of select="."/></p>
</xsl:template>

</xsl:stylesheet>
```

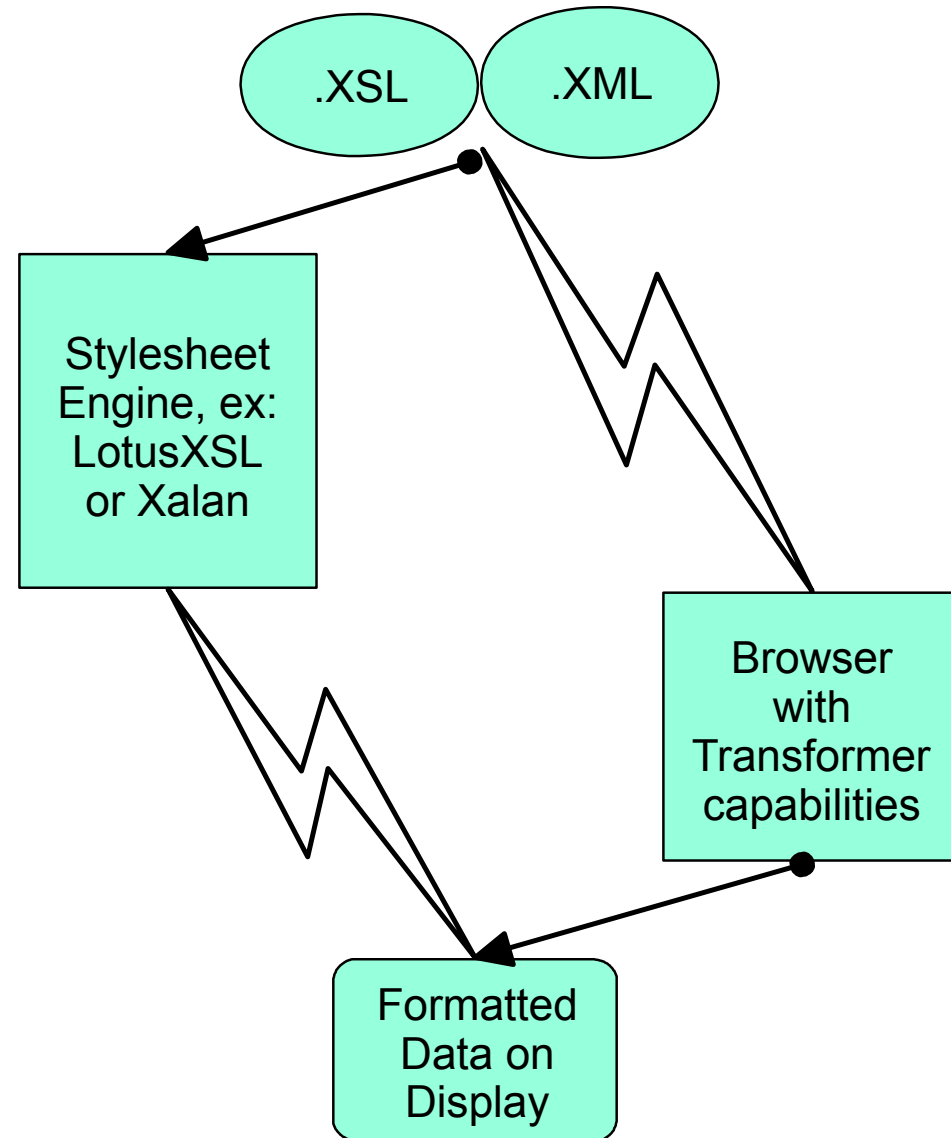

Notes:

This example shows how an XSL document might look. As you can see, it determines how the XML document is to be presented.

The developer uses a set of templates to match certain nodes in the XML document.

Rules can be included which order the presentation of sections - our presentation could be ordered by different elements.

XML Parsers

Well defined syntax and use of DTD (tag definition) enable reusable parsers

- DOM (Document Object Model) - standard API parser support for viewing and manipulating XML documents.
- SAX (Simple API for XML) - event driven. Instead of getting a complete DOM tree, get notifications of arrival at each element.
- makes XML data computer usable/readable

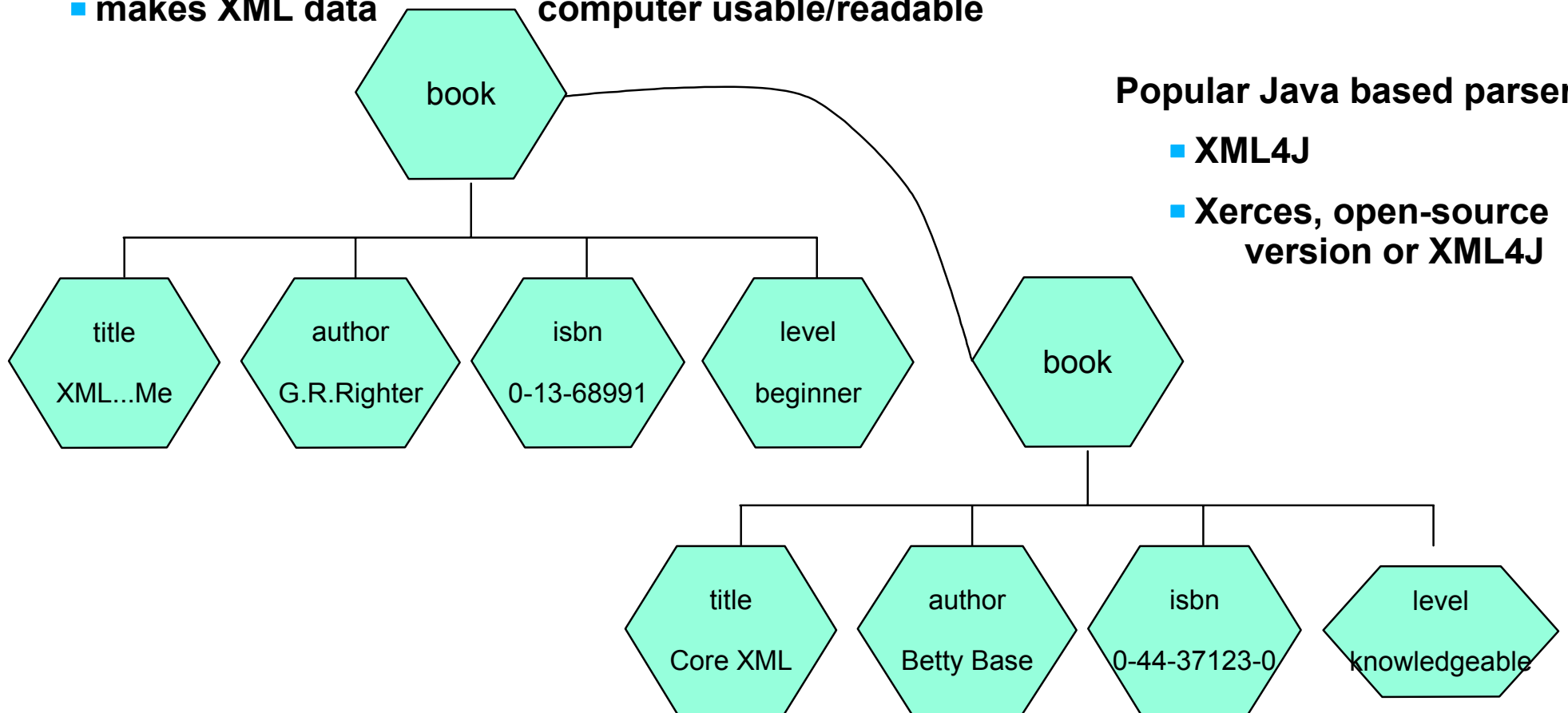

Notes:

IBM has an excellent and very popular XML parser (XML4J for Java and XML4C for C++) available free on the alphaWorks web site. The alphaWorks web site is shown later in the presentation. The alphaWorks team mission is to provide early adopter developers direct access to IBM's emerging "alpha-code" technologies. They make the latest software technologies available for download and evaluation.

The parser allows the XML document to be transformed into a tree which is usable by the computer.

This tree allows easy searching and manipulation of the data within the tree.

The SAX API is another alternative and supported by most Parsers. SAX stands for Simple API for XML - The SAX API is an event driven parser that notifies you when certain events happen as it parses your document. When it encounters a start tag or an end tag, it will present information on those events that your program can process as required. For example, the program could check for the reader level element and change "beginner" to "starter".

Why would you use SAX or XML4J? If your document is very large, using SAX will save significant amounts of memory when compared to using XML4J. This is especially true if you only need a few elements in a large document. On the other hand, the rich set of standard functions provided by XML4J isn't available when you use SAX.

DOM Parser

Document Object Model (DOM)

W3C Recommendation

Uses a "tree" representation of an XML document

- Tree is created as a result of parsing a document
- Navigates tree by node

SAX Parser

Simple API for XML (SAX)

A de-facto standard by Dave Megginson, not from W3C

Event based parser presents elements as encountered

- Instead of getting a complete DOM tree, get notifications of arrival of each element
- Less memory required, suitable for large documents

Support available from XML4J & Xerces parsers

Defines a number of events, you can write code to implement behaviors for each. Examples:

`startDocument()` & `endDocument()`

`startElement(String elementName, AttributeList attrs)` &
`endElement(String elementName)`

`characters(char ch[], int start, int length)`

Some Other XML Technologies

Namespaces

- W3C recommendation 01/1999
- collection of names, identified by a URI reference [RFC2396], which are used in XML documents as **element** types and **attribute** names
- Analogous to a field reference

XLink - XML Linking Language

- W3C Recommendation 1.0, June 27th 2001
- Link XML elements among separate XML documents
 - simple links similar to HTML `<a href="http://www.w3c....."`
 - more sophisticated links, bi-directional, etc.
- Reduce data redundancy and functional dependencies
 - Sounds familiar?
 - Analogous to DB normalization at 3NF?

Some Other XML Technologies

XPointer

- W3C Candidate Recommendation 09/11/2001 - 03/04/2002
- Based on the XML Path Language (XPath), supports addressing into the internal structures of XML documents, identified by URIs (Uniform Resource Identifiers)

SOAP (Simple Object Access Protocol)

- simple and lightweight mechanism for exchanging structured and typed information between peers in a decentralized, distributed environment using XML
- ```
<SOAP-ENV:Envelope
xmlns:SOAP-ENV="http://schemas.xmlsoap.org/soap/envelope/"
SOAP-ENV:encodingStyle="http://schemas.xmlsoap.org/soap/encoding/">
<SOAP-ENV:Body>
 <m:GetLastTradePrice xmlns:m="Some-URI">
 <symbol>IBM</symbol>
 </m:GetLastTradePrice>
</SOAP-ENV:Body>
</SOAP-ENV:Envelope>
```

# XML - datastreams to various devices

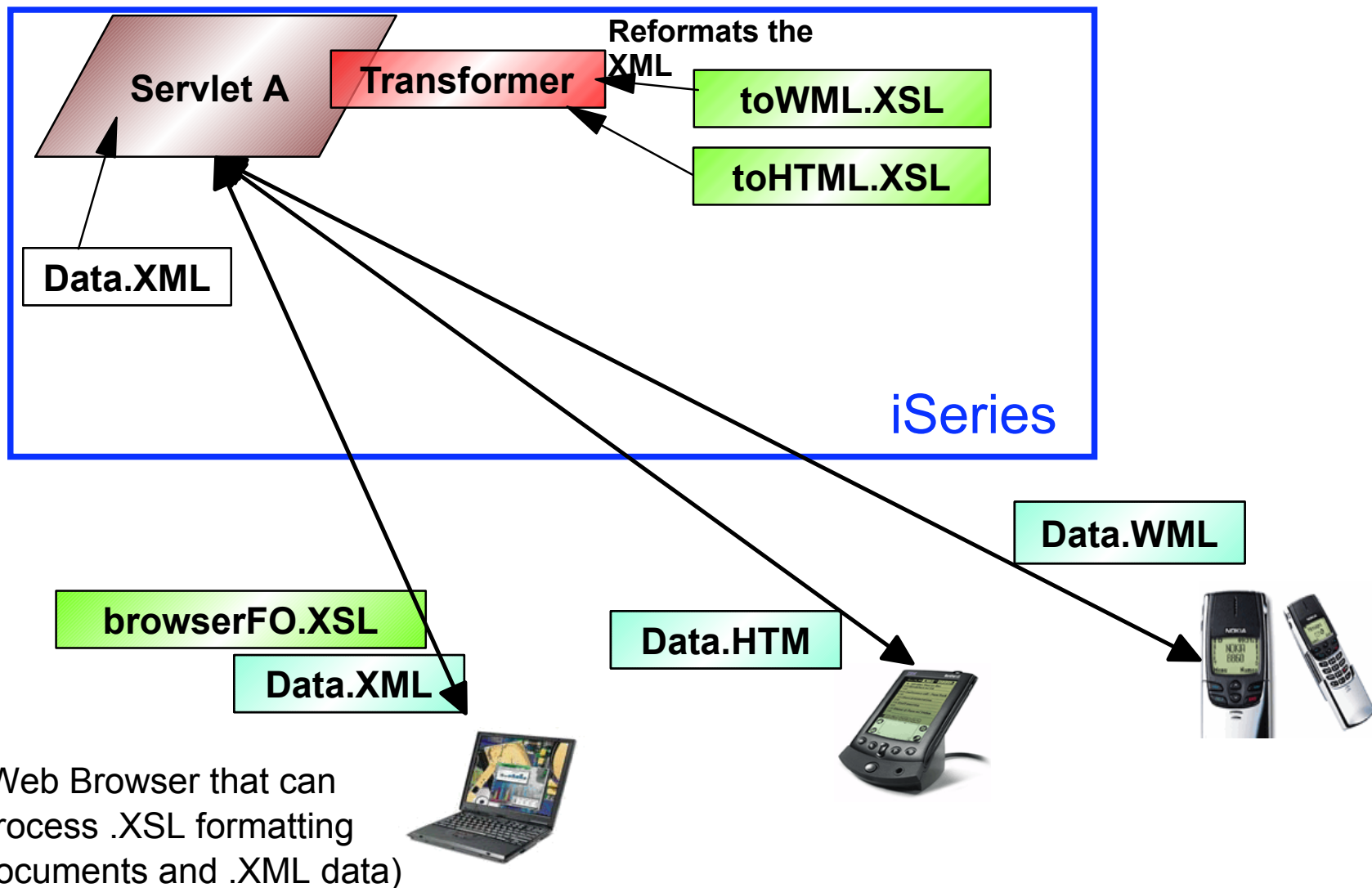

# Notes:

This example shows the use of a common XML document used by a variety of devices. This is accomplished by using XSL and the transformer.

The device could invoke a servlet on an iSeries by using a user-agent to determine the device. The servlet could then invoke the XSL transformer to reformat an XML document using an appropriate XSL stylesheet and create a resulting document that could be sent to the requesting device.

# Example: Between applications

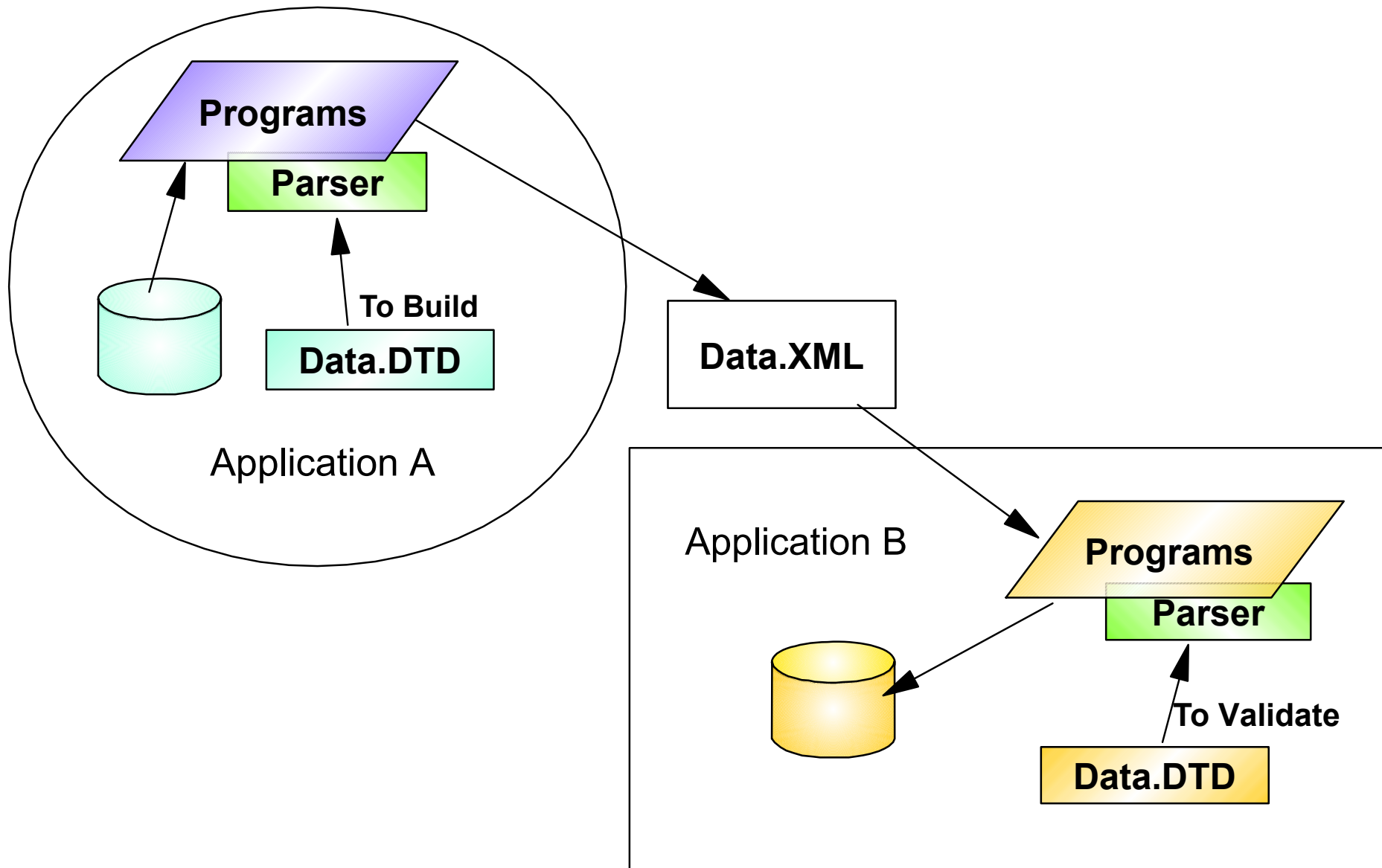

# Notes:

In this example, two different applications utilize XML. The programs use the DTD to ensure the XML document format created in the first program and sent to the second program meets the specifications for that data exchange.

Application A has a class/program that uses the parser to take data from a datastore to create an XML document. The parser uses the DTD to ensure the document is valid.

Application B has a program that processes the XML document by using the parser to read the document. The DTD is used by the parser to validate the document.

These two XML enabled applications could be used within a single company or they could be two XML enabled applications used by different companies using XML as the exchange format.

# Example: B2B (unique XML dialects)

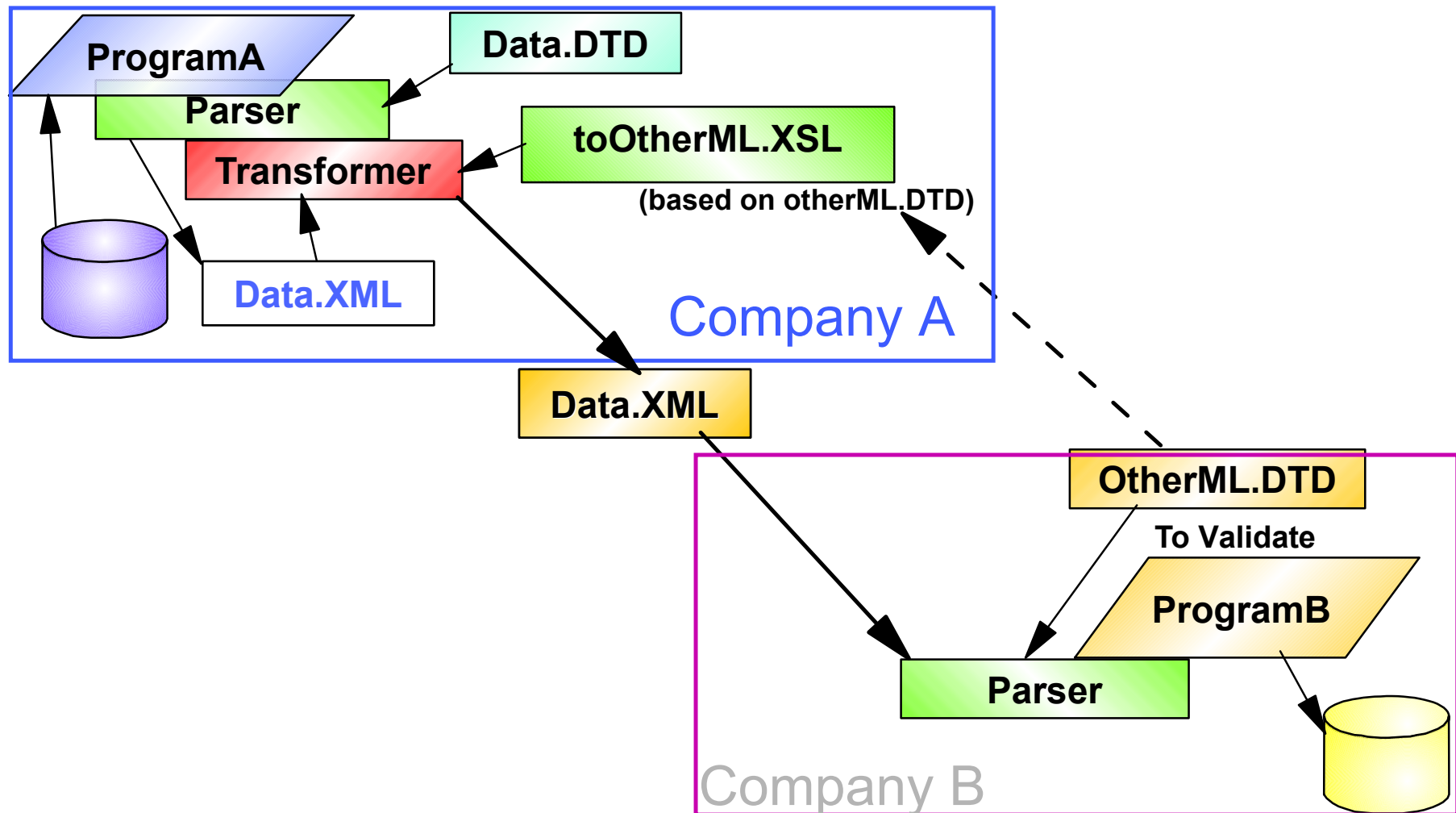

# Notes:

This could be an example of a Business to Business (B2B) data exchange.

This example shows two companies that are communicating using XML to express the data.

Normally, they would use a common XML dialect. However, this picture show the two companies using different XML dialects. Communication is simplified by using XLS and the transformer.

Company A has created an XSL document with the rules to transform their XML data to the other dialect and a program to create an XML document using that stylesheet and an XSL transformer to the other dialect.

Company B can validate that XML document using the parser and their copy of the DTD.

# Web Services

"The Web Services Architecture defines the basic principles and functions required for such dynamic business interactions, including the ability to **publish** to a server, **find** a particular service and **bind** to it programmatically through the use of standards"

Web services are self-contained, modular applications that can be described, published, located, and invoked over a network. Web services could be weather reports or stock quotes. Transaction Web services, supporting business-to-business (B2B) or business-to-client (B2C) operations, could be airline reservations or purchase orders.

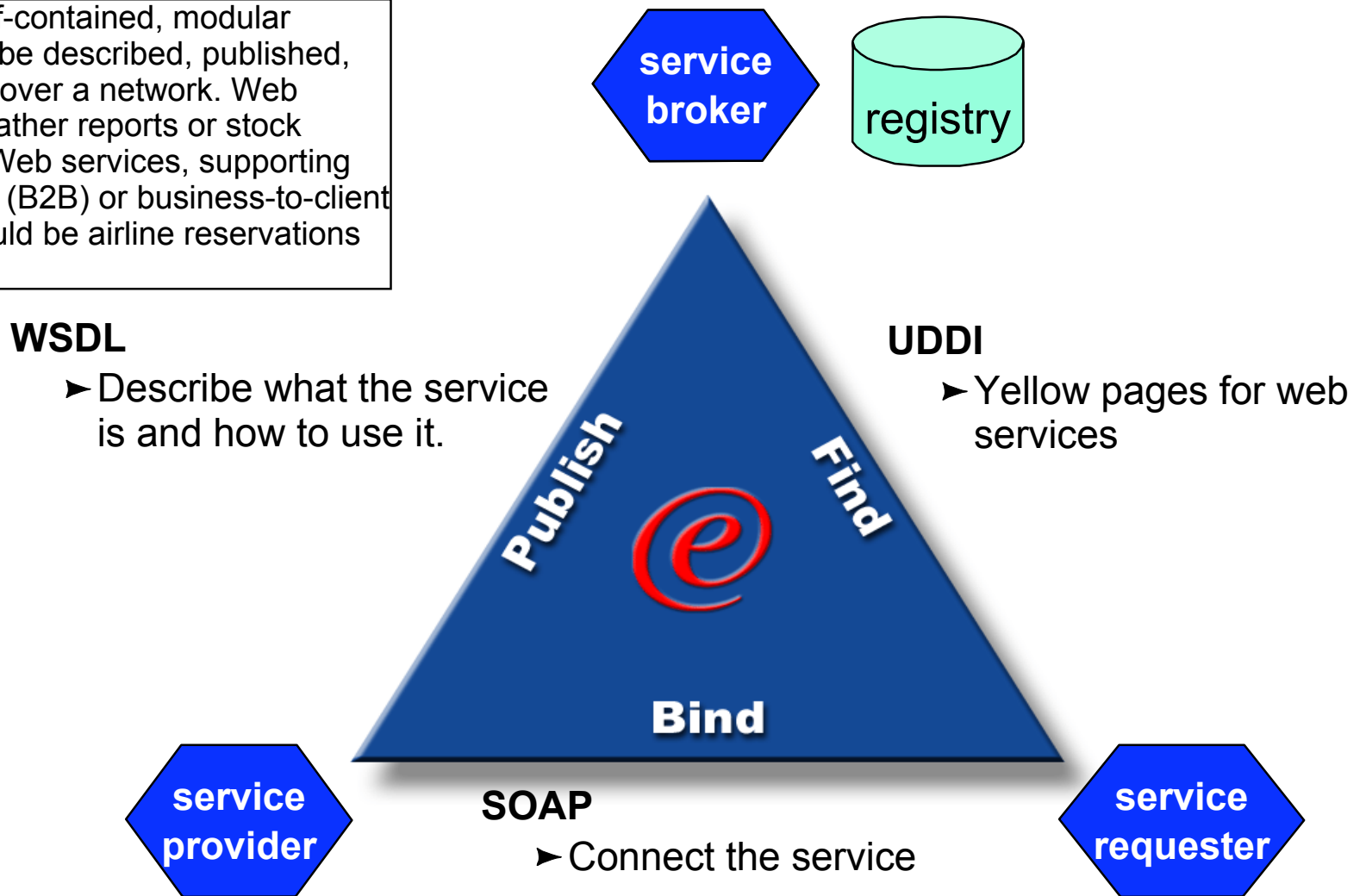

RPG, COBOL, C, C++, CL programs can provide web services  
iSeries WAS Express also includes DB2 Web Services sample application

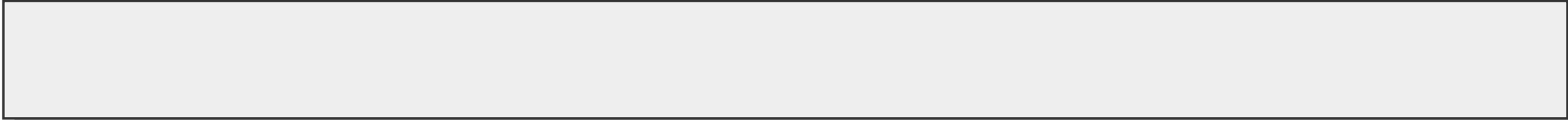

Web services are self-contained, modular applications that can be described, published, located, and invoked over a network. Web services could be weather reports or stock quotes. Transaction Web services, supporting business-to-business (B2B) or business-to-client (B2C) operations, could be airline reservations or purchase orders.

Web services reflect a new "service-oriented" approach to programming, based on the idea of building applications by discovering and implementing network-available services, or by invoking available applications to accomplish some task. This "service-oriented" approach is independent of specific programming languages or operating systems. Instead, Web services rely on pre-existing transport technologies (such as HTTP) and standard data encoding techniques (such as XML) for their implementation.

The Web services architecture describes three roles:

- Service provider
- Service requester
- Service broker

Web services components provide three basic operations:

- Publish
  - Web services must be published so they can be later discovered
  - service brokers provide registry related services
  - UDDI can be used for discovering a Web service
  - Service providers publish their services in a registry
  - process depends on the type of registry; UDDI, database, file system
  - UDDI registries can be available on the Internet or Intranet
  - IBM and Microsoft provide UDDI registries on the Internet
  - UDDI registries can be accessed via a Web browser or programmatically
  - UDDI registries are invoked programmatically via SOAP using a UDDI client (UDDI4J for example)
  - Service descriptions are published in the registry
  - WSDL is an XML standard for describing Web services
- Find
  - Published Web services are discovered
  - Service requesters query the registry to find desired services
  - Queries occur either at design time or run time
  - Design time - determine the parameters to be used with the Web service
  - Run time - determine binding information required to invoke the service
- Bind
  - Service requesters invoke Web services by binding to them
  - Service descriptions from the registry provide the binding information
  - SOAP is a standard that can be used for binding to Web services



In order for some component to become a Web service, it must be:

- Created, and its interfaces and invocation methods must be defined
- Published to some repository
- Easy to locate by potential users
- Invoked and implemented by users
- Unpublished when it is no longer available

As illustrated in the graphic,

- Web service descriptions can be created and published by service providers who create on-line resources for personal and business use.
- Web services can be categorized and searched by specific broker services.
- Web services can be located and invoked by requesters of the services.

With Web services, programming complexity is reduced because application designers do not have to worry about implementing the services they are invoking. Interactions in Web services are bound dynamically at runtime. A service requester describes the features of the required service and uses the service broker to find an appropriate service.

WebSphere Application Server supports making the following artifacts into Web services:

#### Java beans

- Enterprise Java Beans
- BSF supported scripts
- DB2 stored procedures

#### IBM TECHNOLOGIES

- UDDI - Universal Description, Discovery and Integration
  - Leader in creation of UDDI project
- Host of UDDI Business Registry
- SOAP - Simple Object Access Protocol SOAP
- Co-author of specification
- Chair of XML Protocol working group in W3C
- Contributor of SOAP4J to Apache open source project
- WSDL - Web Services Description Language WSDL
  - Co-author of specification
- First WSDL toolkit implementation on alphaWorks
- WSFL - Web Services Flow Language WSFL
  - Submitted draft standard for industry approval
  - Describes how web services can be assembled to describe business process or partner interactions

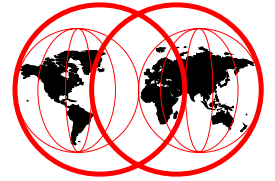

# **XML on iSeries**

# XML and iSeries

## **WebSphere® Application Server (all editions)**

- Includes XML4J (Java™) parser for XML and DTD library
- Includes LotusXSL processor

## **IBM Toolbox for Java (V4R4 onwards) and JTOPEN**

- Panel Definition Markup Language (PDML)
  - ◆ XML used for defining GUI layout and components
  - ◆ Visual GUI builder and tool to convert from Microsoft® GUIs to XML
  - ◆ Runtime to generate Java/Swing GUI from PDML
- Program Call Markup Language (PCML)
  - ◆ iSeries program interface defined in XML
  - ◆ Runtime framework supporting program calls from Java
- Includes XML4J (Java™) parser for XML
  - ◆ XML4J parser used for both PDML and PCML

# Notes:

WebSphere® provides the basic enablers to create XML documents and has plans to increase its capabilities with XML.

On the iSeries, V4R4 utilizes XML in our PDML (Panel Definition) and PCML (Program Call) Markup Languages. They are part of the IBM Toolbox for Java and are ready to use. The toolbox also includes the XML4J parser for working with the XML data.

JTOPEN is the open source version of the IBM Toolbox for Java

PDML (Panel Definition Markup Language) - a user interface framework to provide a productive development environment for building graphical panels. The framework automatically handles the exchange of data. The developer only needs to create one or more data beans and bind them to the panel components using PDML tags.

PCML (Program Call Markup Language) - a program-called framework, provided via a tag language used for supporting the program call function of the toolbox. The language fully describes all parameters, structures, and field relationships necessary to call an iSeries program.

iSeries development is using them today to create GUIs for the iSeries and to call between Java and other languages.

We use the IBM XML parser to interpret the PDML and PCML documents.

# XML and iSeries

## XML Toolkit for iSeries (5733-XT1)

To ensure latest versions of Apache XML parsers, currently Apache Xerces 1.6

- Includes XML Schema support

### XML Parser for C++ (XML4C 4.0)

- Service program QXMLTOOLS/QXML4C400
- is available at <http://www.alphaworks.ibm.com>

### XML Parser for Procedural Languages (XML4PR 4.0)

- COBOL, RPG, C
- Service program QXMLTOOLS/QXML4PR400
  - ◆ Facilitates the use of XML as both a datastore and IO mechanism in these languages.
  - ◆ XML version 4.0 parser API documentation, sample, and include files. The C, RPG, and COBOL development environment is installed in library QXMLDEV400. The C++ development environment is installed in the integrated file system directory

# Notes:

In addition to the XML4J - the Java parser, a C++ parser for XML is available through IBM's alphaWorks web site at <http://www.alphaworks.ibm.com> for download, evaluation and use. Having both Java and C++ XML parsers provides more opportunity for customers/solution developers to incorporate XML enhancements in their current application programs. There is also an XML Interface for procedural languages, XML4PR.

As of V5R1, these are now packaged and supported in XML Toolkit for iSeries (5733-XT1). This ensures that the latest supported versions of the C++ and procedural parsers will be available.

# What is an Application Server?

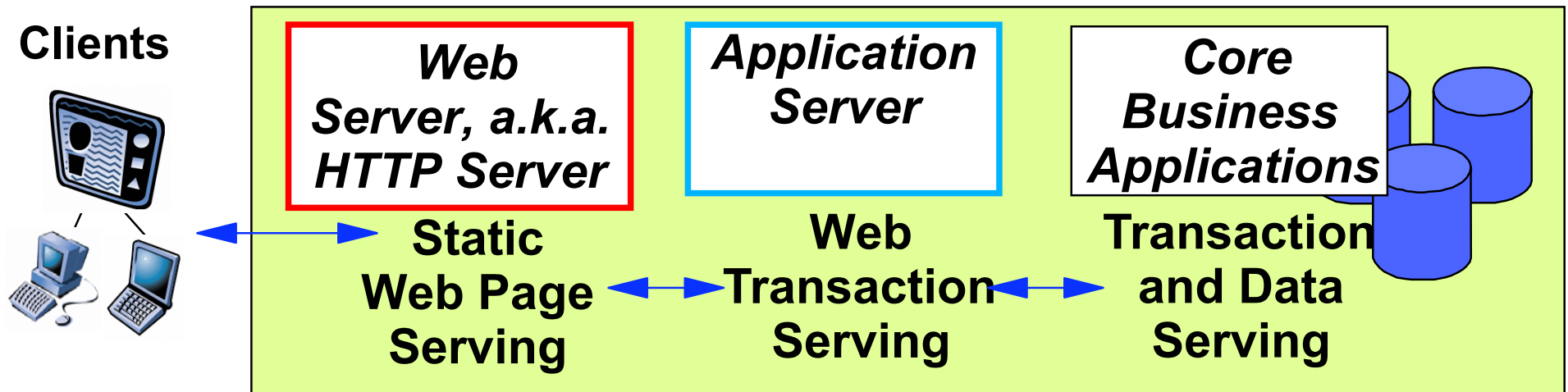

## Web/HTTP server

- Provides pages (UI) to the browser

## Application server

- Mediates between Web and business applications
- Runs new business logic (filters, rules, etc.) in Java™
- Handles some transaction processing

## Back-end

- Handles most transactions, running the state of the business

# What Does an Application Server Do?

- J2EE™ support
- Transaction Management
- Data Sources
- DB connection pooling
- Clustering & Load balancing
- Session/State management
- Failover support
- Persistence Service
- Security server
- Java Message Service (JMS)
- Name Service (JNDI)
- . . .

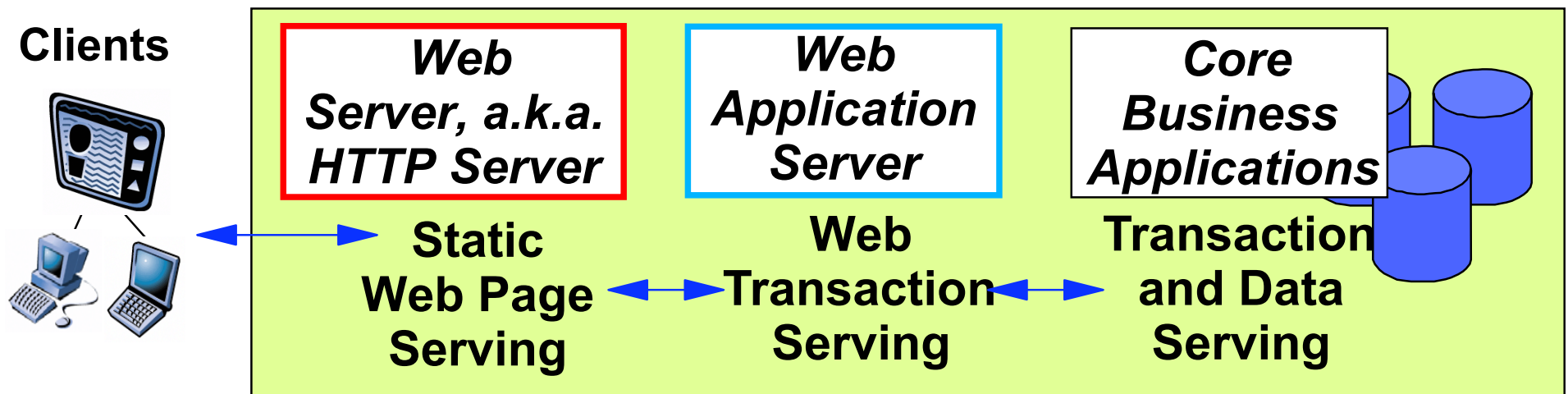

# WAS Network Deployment, Version 5.0

WebSphere Application Server Network Deployment (ND) expands on the functionality of the base product.

WebSphere Application Server Network Deployment adds:

## Distributed systems administration

- single administrative interface to manage
- multiple app servers in a clustered environment
- Presentation of a single-system image
- Distribution of configuration information
- Distribution of applications throughout a
- Network Deployment cell
- Monitoring distributed systems

## Clustering and workload management

- Workload management
- Failover
- Distributed security
- Distributed naming

## Advanced Web services

- private Universal Description, Discovery, and Integration (UDDI) registry
- IBM Web Services Gateway (WSGW) support

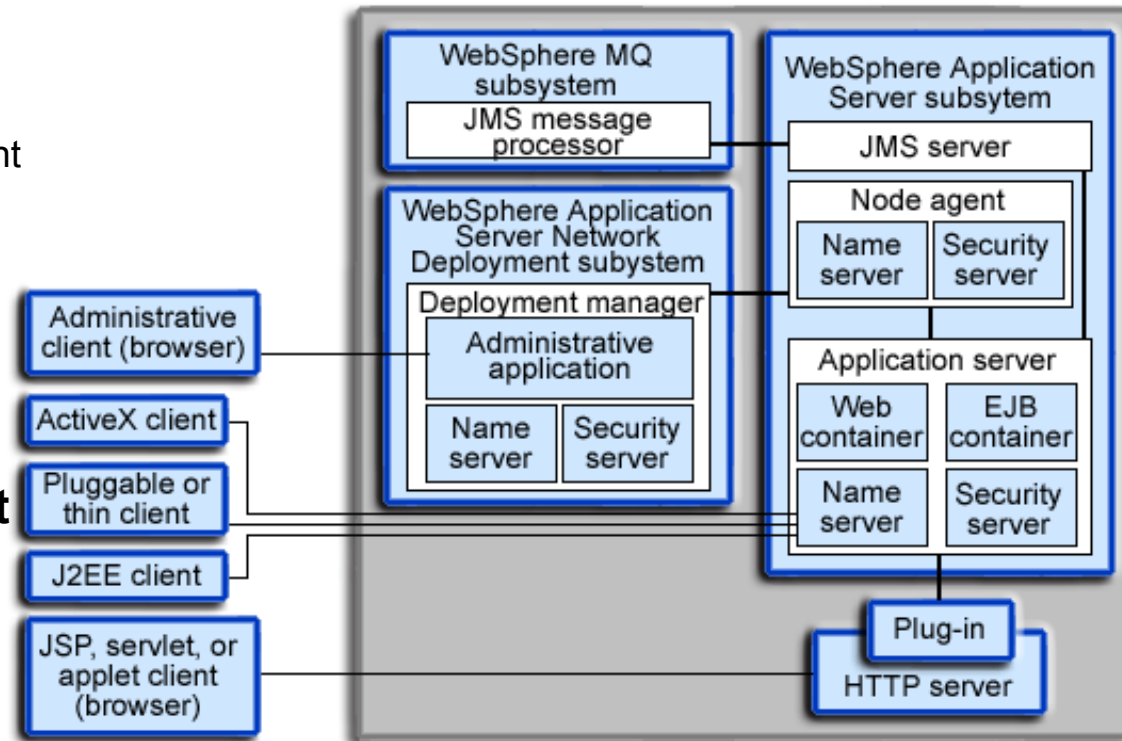

# WAS, Version 5.0 (a.k.a. Base)

The base WebSphere Application Server product, is fully J2EE-compliant and supports single machine environments. Some features:

- Browser-based administrative console.
- All configuration data is stored in XML files.
- Integrated Java Message Service (JMS) server.
  - JMS is part of the J2EE 1.3 specification, and enables asynchronous messaging between application components.
- Dynamic network caching.
- Java Management Extensions (JMX) systems management support (technology preview)
- An ANT-based administrative tool called ws\_ant (technology preview)
- HTTP session state failover support.
- A session manager is integrated into each application server.
- Web services support, including Web Services Invocation Framework (WSIF), WS-Security, and a technology preview of JSR109.
- New security features, including support for JAAS, CSiv2 interoperability, Java 2 security, and third-party security providers.
- The Performance Monitoring Infrastructure (PMI) is integrated with JMX.
- Resource Analyzer has been rebranded as Tivoli Performance Viewer and includes extended functionality.
- Troubleshooting includes First Failure Data Capture (FFDC), which allows you to collect data based on the first failure in the system.
- The collector script gathers system information and packages it in a JAR file that you can send to IBM Service for analysis.

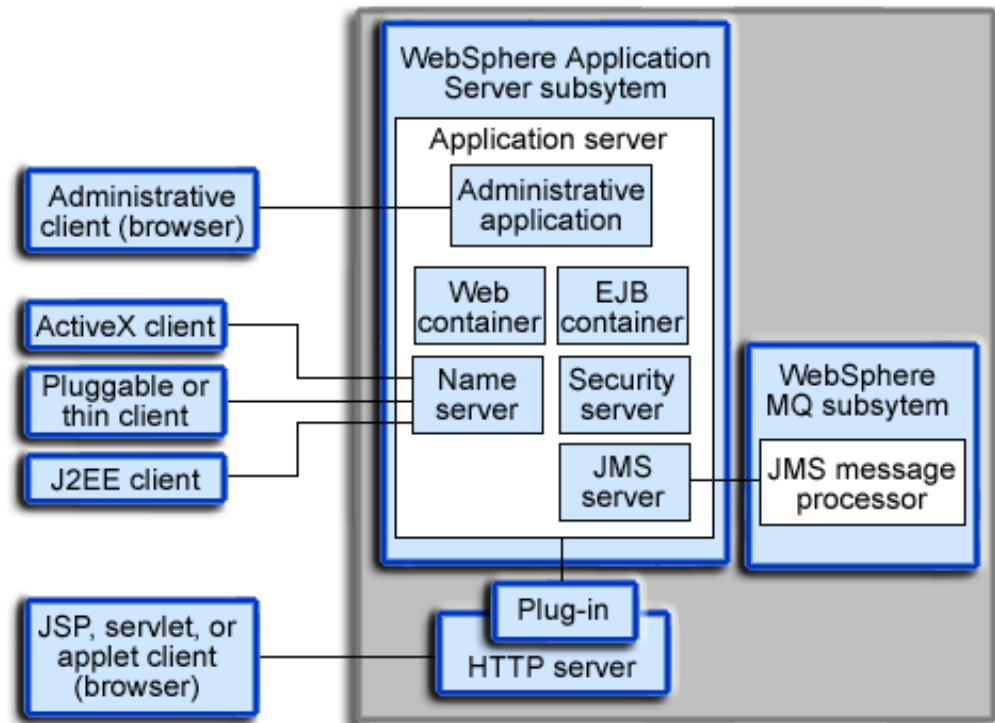

# WebSphere Express vs. WAS V5

|                                                                                                                           | WAS - Express, V5              | WAS, V5        |
|---------------------------------------------------------------------------------------------------------------------------|--------------------------------|----------------|
| Full J2EE 1.3 support to maximize J2EE functionality, including EJBs                                                      |                                | X              |
| Full XML support                                                                                                          | X                              | X              |
| Full Web services support to host and consume Web services                                                                | X                              | X              |
| JDBC and Connection Management for access to DB2, SQL Server™ 2000 and Oracle™ 9i                                         | X <sup>1</sup>                 | X <sup>1</sup> |
| Sample applications                                                                                                       | X                              | X              |
| Simplified administration using WebSphere Studio Site Developer                                                           | X, iSeries WDS <sup>3</sup>    | X              |
| WebSphere Studio Site Developer included                                                                                  | iSeries only. WDS <sup>3</sup> |                |
| Embedded HTTP Server                                                                                                      | X                              | X              |
| Basic authentication and authorization to secure access to Web resources                                                  | X                              | X              |
| Web services client for access to back-end Web services                                                                   | X                              | X              |
| Basic platform support for rapid implementation on Windows, Windows NT, Windows 2000, Linux and OS/400                    | X                              | X              |
| Extended platform support for IBM AIX, IBM OS/400, Sun Solaris operating environment, HP/UX                               |                                | X              |
| Microsoft component object model architecture to EJB support for integration with ActiveX client and server resources     |                                | X              |
| Enhanced features for performance such as dynamic caching, Tivoli® Performance Viewer, integration with third-party tools |                                | X              |
| Advanced authentication and authorization such as JAAS and JCE for enhanced security                                      |                                | X              |
| Support for some J2EE 1.4 features                                                                                        |                                | X              |
| Extended JDBC support for access to Informix™ and Sybase™                                                                 |                                | X <sup>2</sup> |
| Extended HTTP Server included for configuration flexibility and added security                                            | iSeries only                   | X              |
| Browser-based administration for remote administration across firewalls                                                   | iSeries only                   | X              |
| Full Java Message Service (JMS) support message-driven beans, including embedded JMS transport                            |                                | X              |
| Migration tools and assistance                                                                                            | iSeries only                   | X              |

<sup>1</sup> iSeries installed JDBC drivers do not support SQL Server and Oracle 9i

<sup>2</sup> WAS for multi-platforms, not iSeries

<sup>3</sup> iSeries WebSphere Development Studio client (WDS) is a significant superset of WebSphere Studio Site Developer

# iSeries Usage of XML - PDML

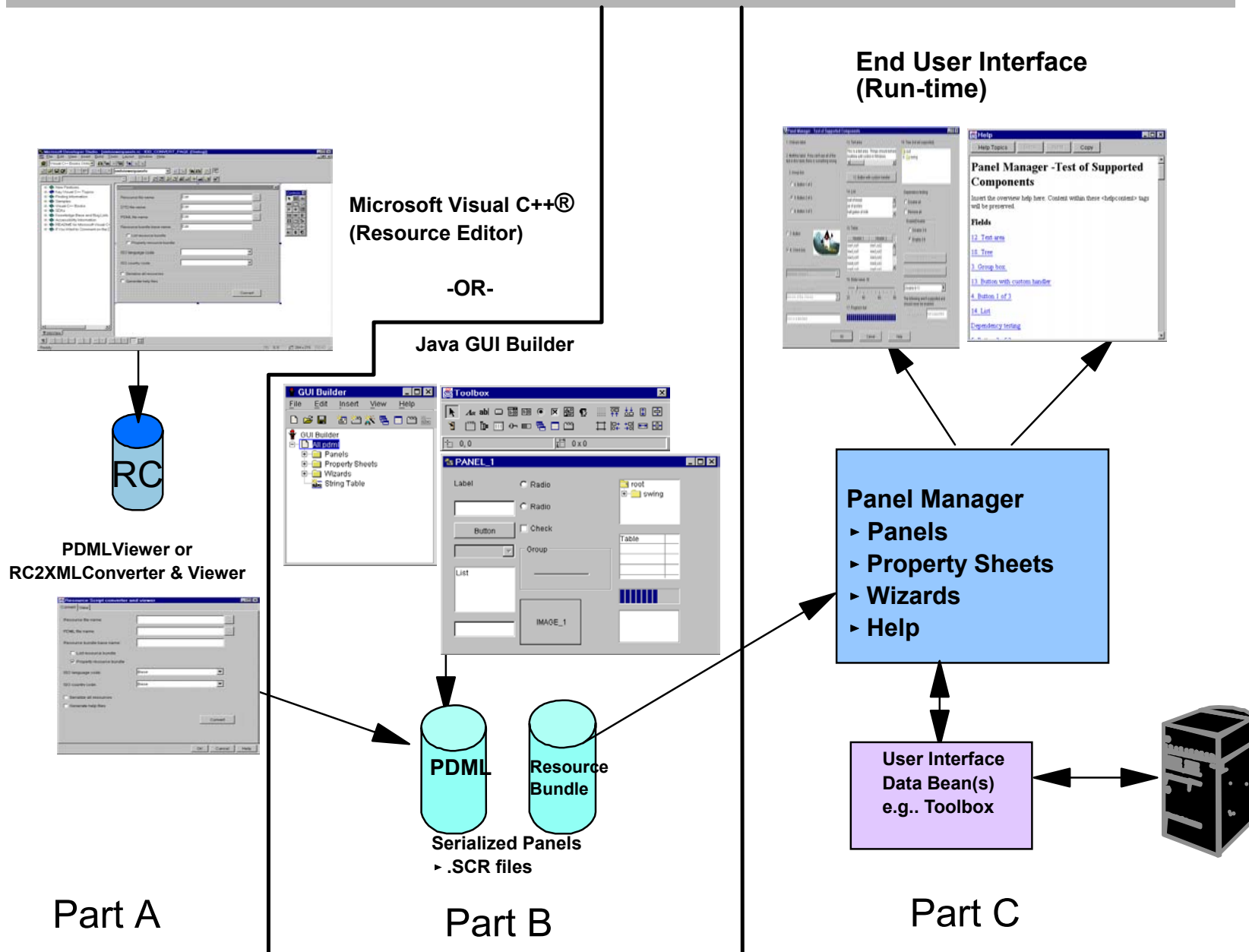

## Notes:

This picture shows how an existing Visual C++ display and a Java GUI can be turned into XML.

The XML can then be processed by the Panel Manager - to display the end user interface in a graphical form.

Part A shows taking an existing Microsoft Visual C++ user interface and using the RC2XML converter to create a PDML document representation of it.

Part B shows using the GUI Builder to design a GUI which is represented as a PDML document.

Part C shows using the PDML and Resource Bundle as input to the Panel Manager at run time. Capabilities in the ToolBox support using the GUIs at run time.

# Displaying your Panels at runtime

## Graphical Toolbox runtime environment

**Handles all data exchange between UI controls & Javabeans identified in the PDML**

**Validates user data**

- common integer and character data types
- allows custom validation

**Defines standardized processing of Commit, Cancel & Help events**

**Manages interactions between UI controls based on state information defined in PDML**

## Notes:

The toolbox runtime environment handles the manipulation of the GUI.

# iSeries Usage of XML - PCML

- Program Call Markup Language
  - ▶ An XML-based language to define iSeries program interfaces
  - ▶ PCML describes an iSeries program interface
    - Used to drive automatic data translation
- `com.ibm.as400.data.ProgramCallDocument`
  - ▶ A Java class representing the interfaces described in a PCML source file
  - ▶ Performs data conversion and program calls to the iSeries

| iSeries data type        | Java data type |
|--------------------------|----------------|
| 4 byte binary            | Integer        |
| Packed decimal           | BigDecimal     |
| Zoned decimal            | BigDecimal     |
| Text                     | String         |
| and all the others . . . |                |

## Notes:

PCML makes communicating from Java to AS/400 legacy applications easier.

By using the ProgramCallDocument class a Java application can send data to and receive data from a legacy application, without have to add extra code.

# PCML - Details

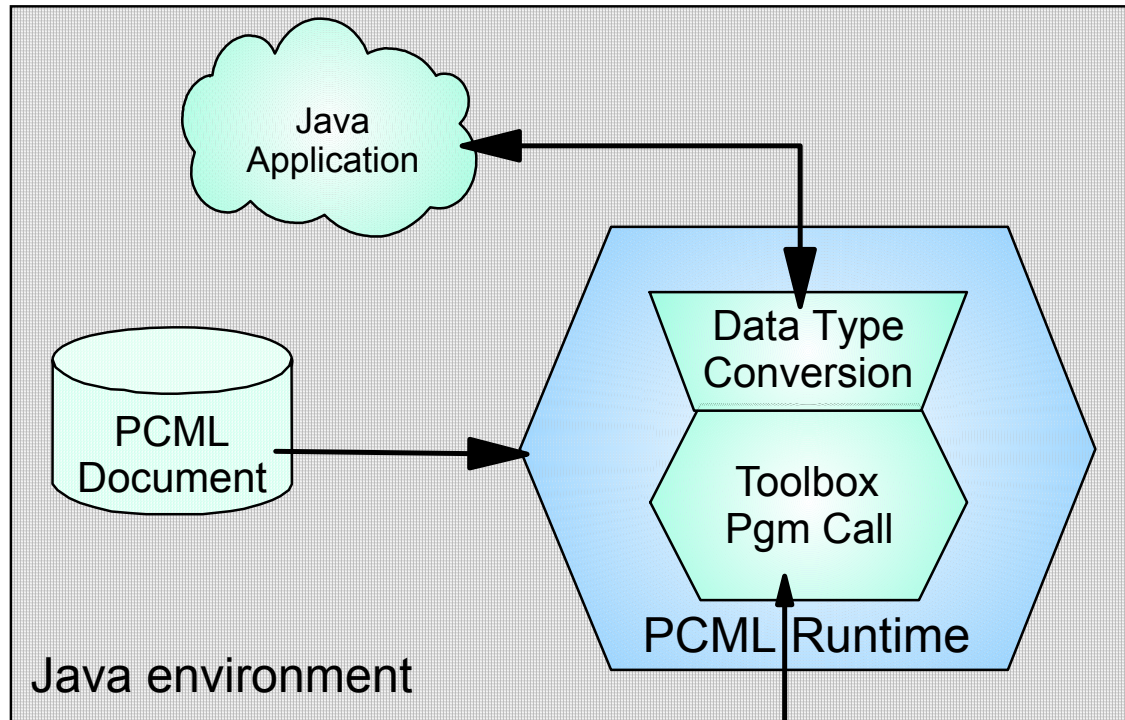

**Define iSeries program interface in XML (location, name, parameters/data types)**

**Use to simplify iSeries program calls from Java**

**PCML runtime handles required data type conversions when interoperating between Java and ILE or OPM languages**

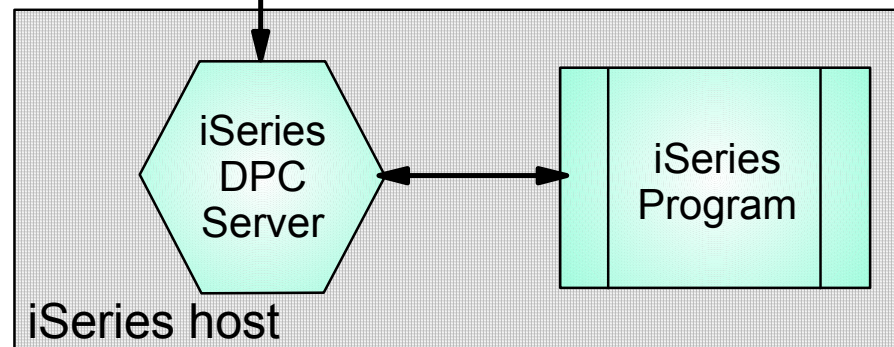

# Notes:

PCML is a tag language that helps you call iSeries programs from Java while writing less JAVA code. This works for both local (same system) and remote calls.

You can describe the input and output parameters for the iSeries program

Previously, to use the Toolbox, the Java developer had to write more to construct the Toolbox calls for performing data translation.

Now your calls for Java to iSeries are automatically handled by ToolBox ProgramCallDocument objects. These ProgramCallDocument objects are generated from the PCML tags.

To increase run time performance, the ProgramCallDocument can be serialized during your product build time.

During runtime, your Java application uses the ProgramCallDocument.setValue() method to set the input values for the iSeries program call. Likewise your Java application uses the ProgramCallDocument.getValue() method to retrieve output from the iSeries program.

# XML/XSL Development Tools for iSeries

- Development tools can assist in definition of XML documents, DTD and XSL
- XML development tools are mostly client-based technologies
- Tools can create XML, XSL, DTD... that can be deployed on iSeries
- Examples
  - [WebSphere Studio Site Developer](#)
    - [Packaged with WDS](#)
  - WebSphere Studio Application Developer

## Notes:

XML and the related enablers have tools that can assist in the definition and utilization of those structures. The tools are client based and create platform independent output. Once created, XML documents, stylesheets and DTDs can be used on the iSeries.

Tools continue to be added and once added, they evolve so it would be appropriate to frequently check for their current capabilities. The web pages are an excellent resource for that information.

# WebSphere Development Studio Client (WDSc) 4.0 \*

## WebSphere Development Studio

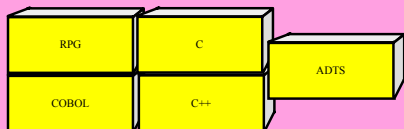

Free upgrade from WDT!

5722-WDS Refresh code 2655

Host

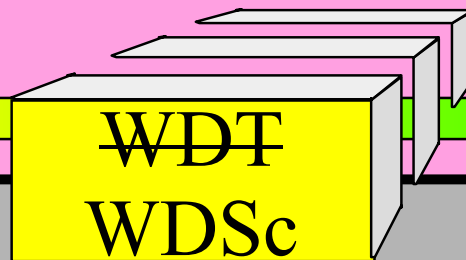

## WSSDa + iSeries Tools

Client

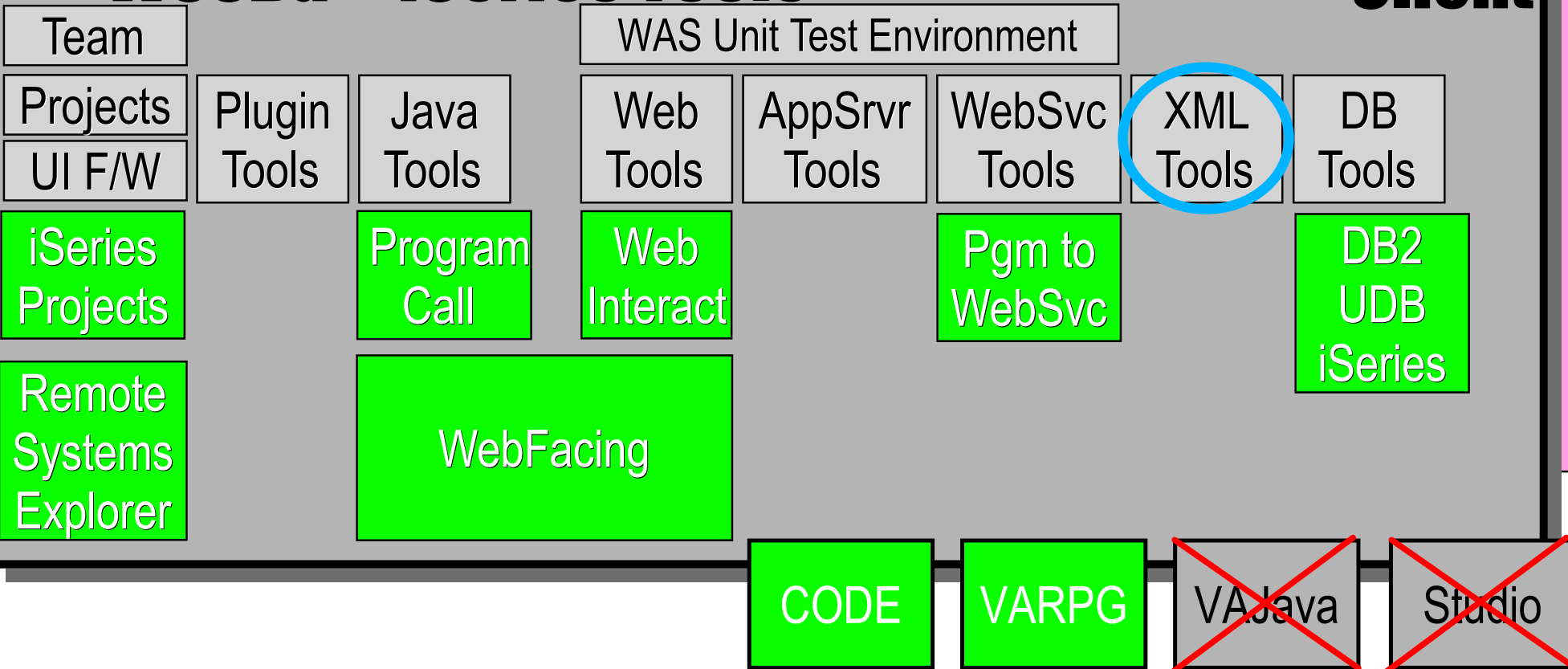

\* Version 5 development tools 1Q 2003

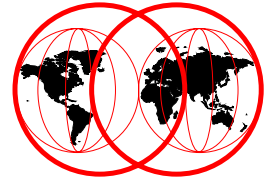

# Supplements to XML on iSeries

# XML for iSeries Objectives

**Establish iSeries as a fully enabled platform for exploitation of XML technologies:**

- Business-to-business transactions using XML for data interchange
- Business-to-user provide business data in XML for viewing
- Keep the iSeries easy to use for Appl. Development and system administration tasks
  - ◆ Example: provide a logical view of relational schema (ala DDS)

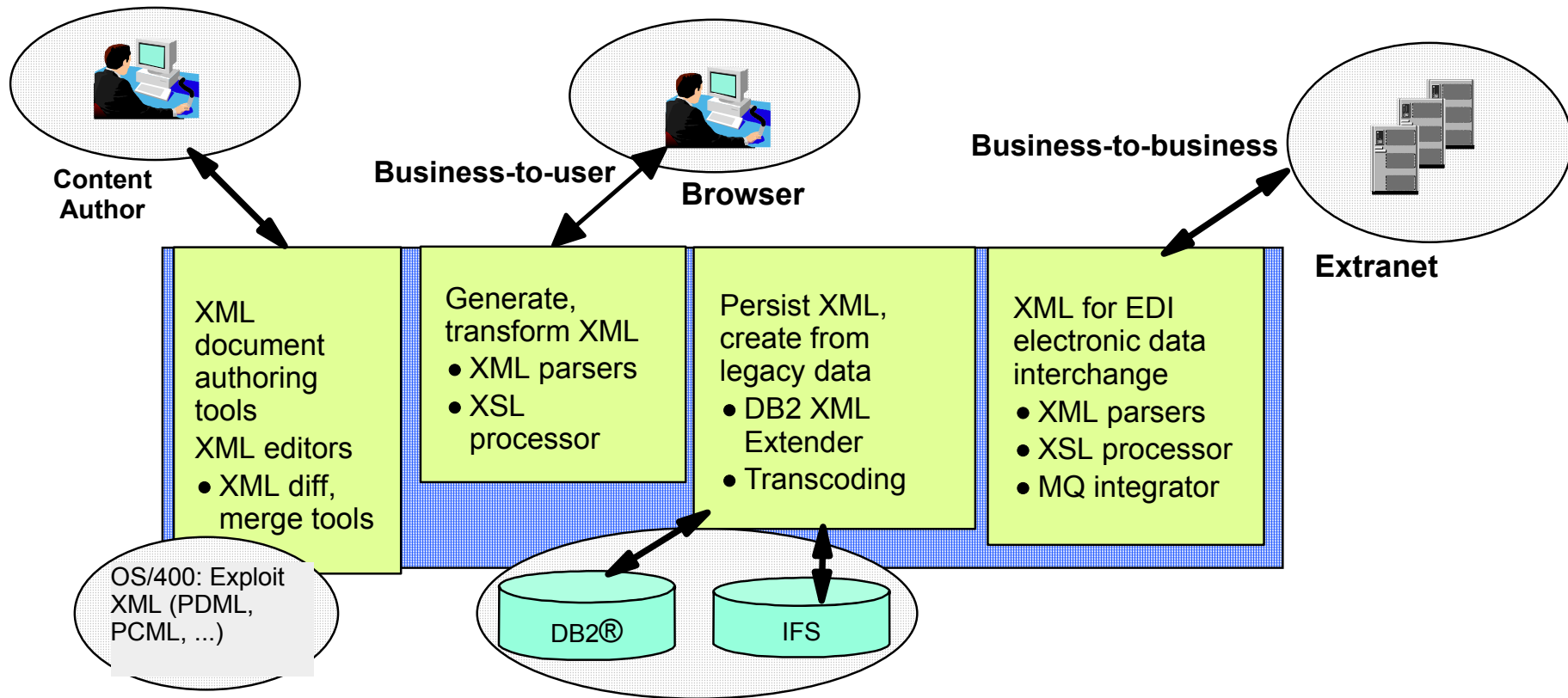

# Notes:

iSeries is a system built for business. We see XML as a key player in new e-business application environment.

There are at least three ways for businesses and the iSeries to take advantage of XML:

- **Business to Business** by providing a vendor and application neutral interface between businesses and business applications, everyone benefits by making the data easy to accept and process.
  - company to supplier data exchange
  - financial transactions
  - insurance
  - ...
- **Business to User** having business information represented in XML enables:
  - presentation by user preference
  - more specific searches
- **iSeries Application Development** made even easier
  - by improving using XML we plan to make information about the iSeries easier to use
  - DDS has been the way to express Data structures and Displays with XML this can be made platform neutral while remaining easy to develop

# DB2 UDB XML Extenders

**XML represents a fundamental change in computing ... away from proprietary file and data formats to a world of open interchange**

**XML = portable data**

**DB2 UDB provides stability, scalability and security**

**Your mission-critical business data is currently stored in DB2 UDB**

**Where do you store your XML documents?**

**How can you convert your business data into XML documents?**

**How can you turn the XML data into database data?**

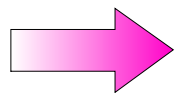

**Answer: DB2 UDB for iSeries Extenders**

# DB2 UDB XML Extender

## XML Extensions to DB2 UDB

- Focus on interchange between data in XML and relational format
  - Map XML data elements to tables/columns in DB2
  - Reconstruct XML document from DB2 data

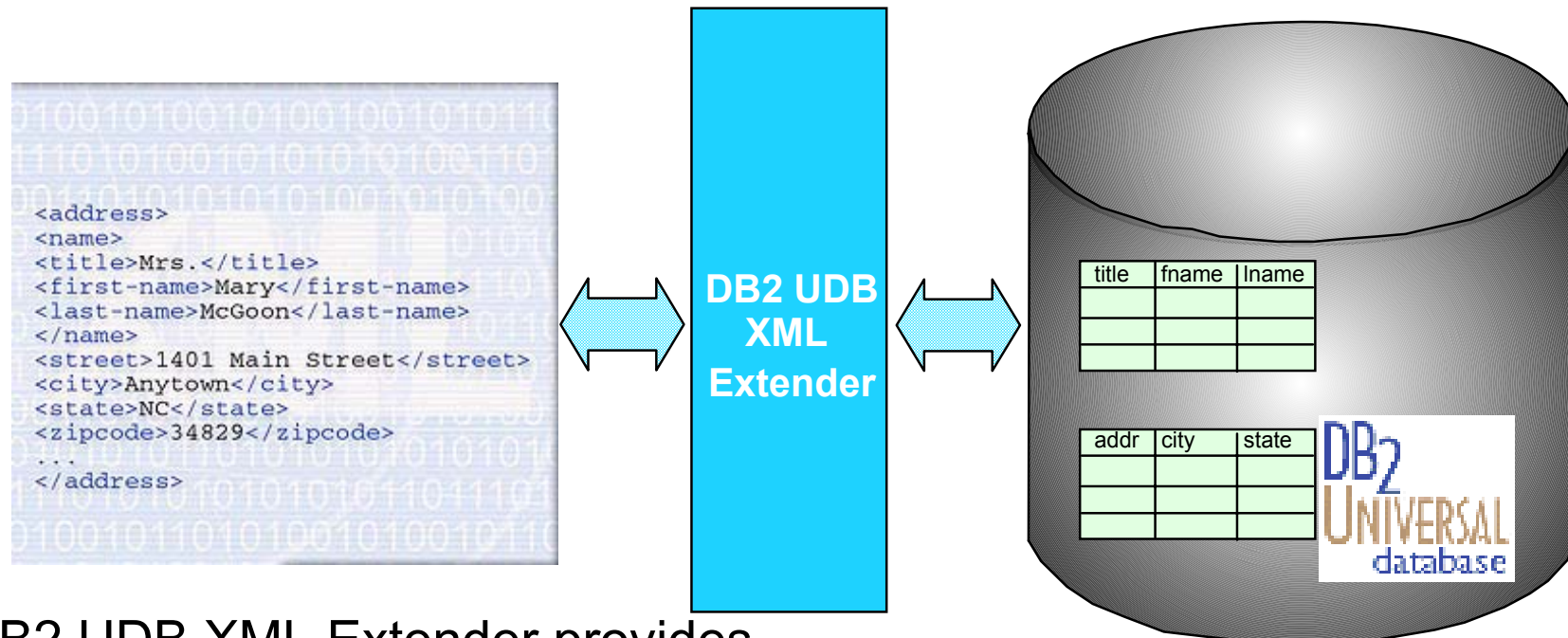

DB2 UDB XML Extender provides

- new data types that let you store XML documents in DB2 UDB databases
- new functions that assist you in working with these structured documents

# iSeries Navigator for Wireless

**Manage multiple systems in a wireless fashion from mobile devices**

- PDA
- Cellular Phone (WAP)

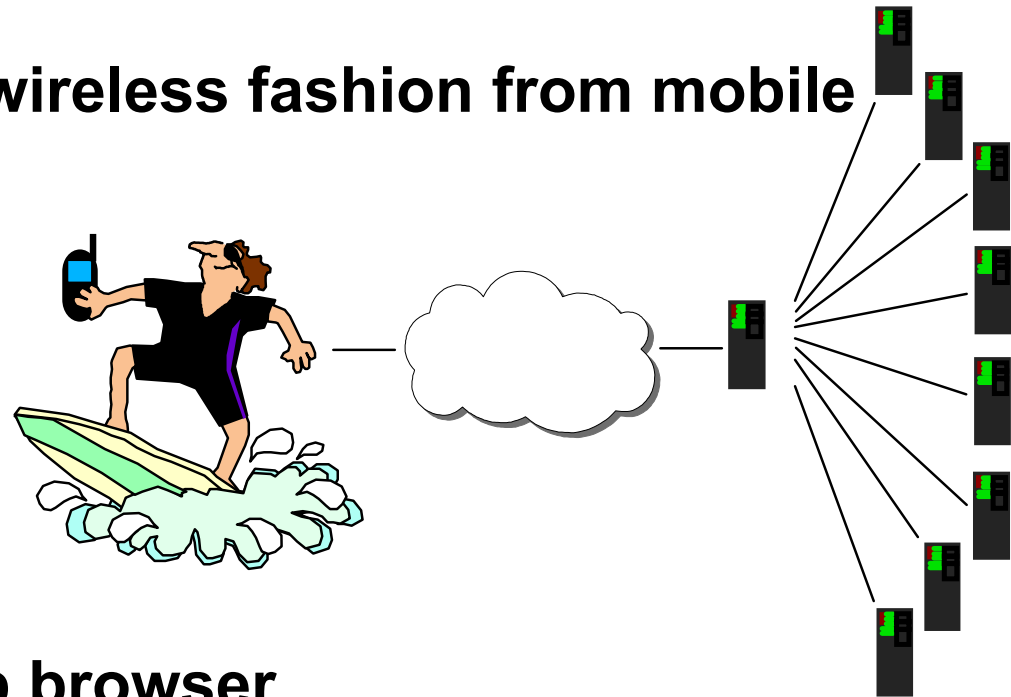

**Also runs in a workstation Web browser**

**Provides a subset of the Management Central capability**

**V4R5 availability**

**Additional capability in V5R1, V5R2**

# iSeries Navigator Functional Details

Watch System Status of iSeries Systems

Monitor Performance on Multiple Systems

**View real-time performance metrics**

**See if thresholds have been reached/exceeded**

**View top 20 jobs (or other related detail) contributing to each metrics**

**Start/Stop monitors**

Monitor Specific Jobs and Servers on Multiple Systems

**View job-level and summary-level metrics in real-time**

**See if monitors have triggered (job failures, exceeded thresholds)**

**Start/Stop monitors**

Monitor Message Queues on Multiple Systems

**View job-level and summary-level metrics in real-time**

**See if monitors have triggered**

**View message details, reply to message, delete message**

**Start/Stop monitors**

Hold, Release or End a Job on any Endpoint System

Run Commands on any Group of Systems

**Choose from your predefined list of MC commands**

**Enter the command from the device**

**View distributed task status**

Manage Integrated xSeries Servers

**View status of lxS servers**

**Startup/Shutdown servers**

**Run NT commands**

**Monitor lxS events (routed to an iSeries message queue)**

Start and view File and B2B Activity monitors

Work with all iSeries Navigator tasks (not just command tasks)

View a summary report off-line

Control access to functions via Application Administration

Use Setup scripts to configure web application servers!

Improved internationalization

V4R5

V5R1

V5R2

# iSeries Navigator for Wireless

Arrow indicates the item selected for drill down

Immediate indicator of a problem using the bell



*CPU Monitor* appears to need attention.  
Select 'CPU Monitor' to drill down and see the system list

*Monitors* appear to need attention.  
Select 'Monitors' to drill down and see the monitor list

*System1* is where the threshold occurred.  
Select 'System1' to see the specific metric information such as CPU avg

# IBM Connect for iSeries 5733-B2B

## Version 2 (5733-CO2)

- Many XML vocabularies, more transaction types

## A B2B Software Integration Framework

- Integrates your business applications with those of your trading partners
- Supports cXML, mXML and other trading partner protocols
- Provides connectivity to existing back-end applications

## Targeted for the sell side of B2B

- Buyer/Supplier Registration tools
- Catalog Services
- Integration with WebSphere Commerce Suite

## Focused on Small to Mid Market requirements

- Low cost
- Easy to deploy with minimal service costs
- Integrated tool set

# Connect for iSeries Overview

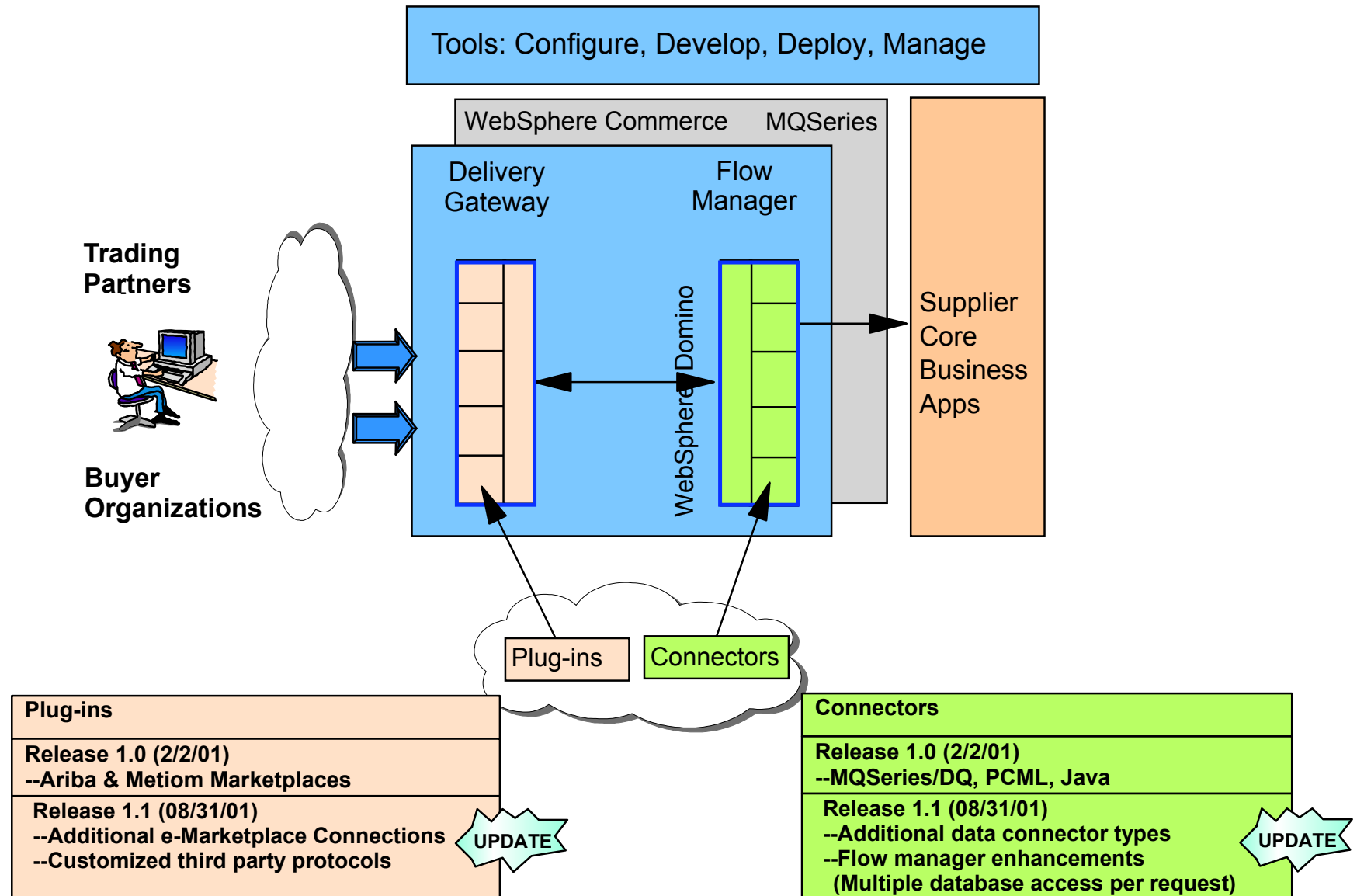

<http://www-1.ibm.com/servers/eserver/iseries/btob/connect/>

## Notes:

Extending DB2 to support XML, allows storage and retrieval of XML documents making the information immediately usable.

# XML and iSeries Summary

**XML - a core technology for data oriented and web-based applications.**

**XML Strategic instrument for defining corporate data across application domains**

- platform, vendor and language neutral
- open and create own meaningful tag set

**Core support to start using XML is available on iSeries**

- WebSphere® Application Server
- IBM Toolbox for Java.

## Notes:

IBM and iSeries are committed to support XML through currency with evolving standards and enabling use of XML through a variety of IBM software and middleware offerings.

# XML - Connecting all the parts

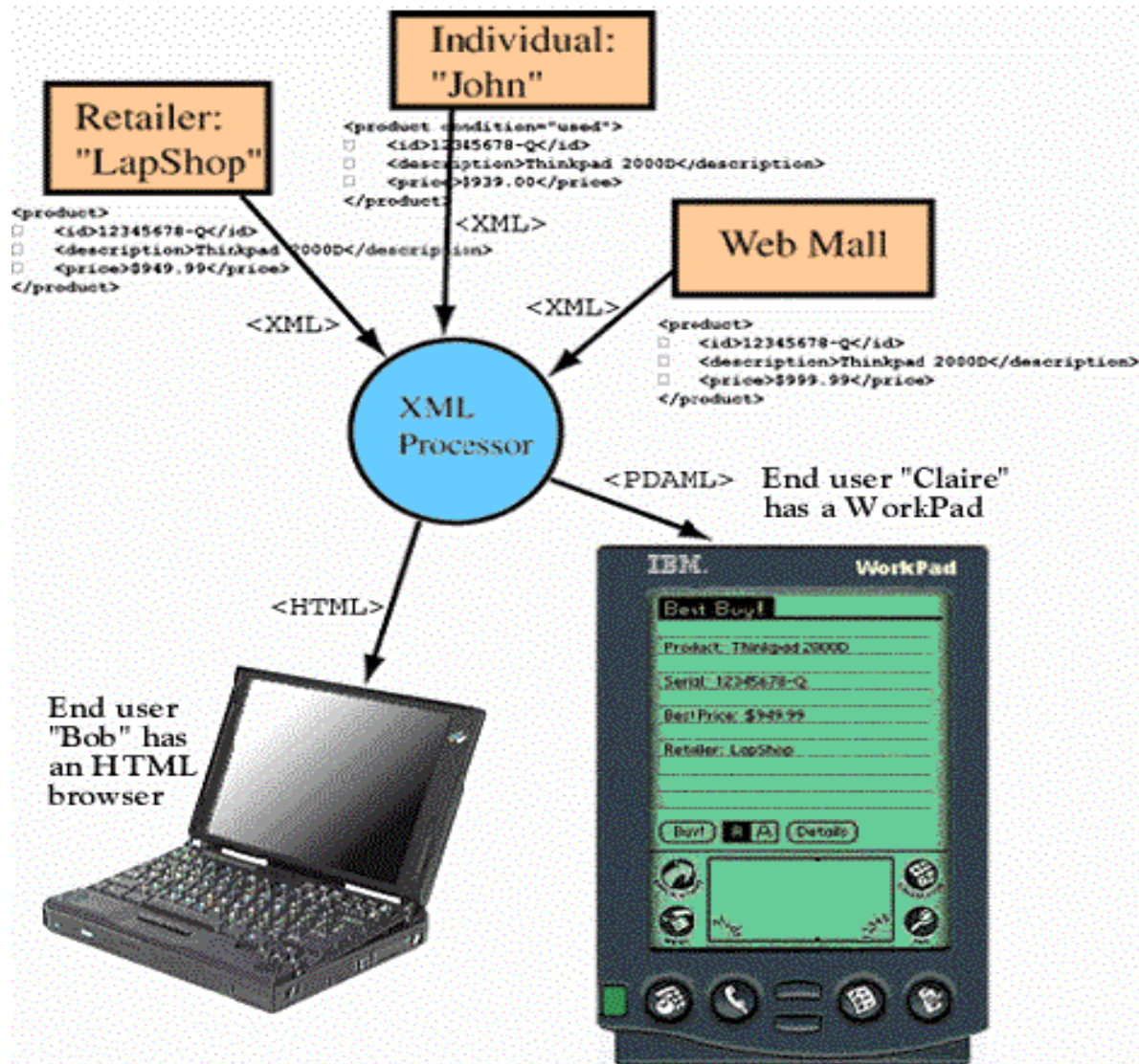

# Notes:

This picture is a summary of all the components required for an XML implementation... XML, a parser, XSL, stylesheets, DTDs and the device protocols to use... But once implemented, this picture shows the tremendous flexibility available with XML in reusing data created once for a variety of users in a variety of formats.

# Additional Information - web resources

## IBM alphaWorks:

- Latest tools and enablers supporting XML
- <http://www.alphaWorks.ibm.com/>

## IBM Toolbox for Java:

- Additional information on PDML and PCML
- <http://www.iSeries.ibm.com/toolbox>

## W3C - XML standards and specifications:

- Status and detail on various XML-related standards
- <http://www.w3.org/XML/>

## IBM - developer education:

- General Information and tutorials
- <http://www.ibm.com/developer/XML/>

## IBM iSeries & XML

- <http://www.iseries.ibm.com/developer/java/xml/index.html>

# Notes:

alphaWorks is the IBM site working with the latest IBM technologies. XML and the related enablers are all discussed on this page and you can keep track of the support provided by IBM.

The IBM Toolbox for Java page delivers the latest information specifically for iSeries.

The W3C pages let you in on the latest developments of the XML and related enabler specifications.

For more on IBM's XML education offerings, check out the tutorials and support information available on the IBM XML page.

# Additional Information - web resources

## OASIS - Organization for the Advancement of Structured Information Standards:

- Standards for defining data documents exchanged between businesses
- Mission: to simplify business information exchange
- <http://www.oasis-open.org/>

## XML/EDI

- A grass roots advocacy for use of XML and EDI together
- <http://www.xmledi.com/>

## Open Applications Group:

- Promote the easy and cost-effective integration of key business application software components
- <http://www.openapplications.org>

## XML.org:

- Information on XML standards, tools & developments in XML
- Repository for industry standard DTDs that may be shared across companies
- <http://www.xml.org/>

# Notes:

The XML.org page is one that shows progress in definition of industry standard DTDs. This is an excellent page to catch up on how others in a specific industry are using XML by their DTDs or just see how others are using XML if your specific industry is not yet represented.

# XML and iSeries Summary

## **XML and Java Developing Web Applications**

- Hiroshi Maruyama, Kent Tamura, Naohiko Uramoto
- ISBN 0-201-485435

## **XML Bible**

- Elliotte Rusty Harold
- ISBN 0-7645-3236-7

## **Project Cool - Guide to XML for Web Designers**

- Teresa A Martin
- ISBN 0-471-34401

## **The XML Files: Using XML and XSL with IBM WebSphere® 3.0**

- IBM Redbook
- SG24-5479-00

# Notes:

Finally, here are some books that have been helpful in our understanding of XML. There certainly are others and you should check them to make sure they will meet your needs...